

CORE PRO COOKING



Gas Salamander Broiler

Model Numbers: CP-SM-36

Core Pro Cooking™ Salamander Broiler

The Core Pro Cooking™ Salamander Broiler provides 3-level broiling positions ideal for beef, chicken, and fish products. Powerful infrared burner ensures even heat distribution and customer satisfaction.



CP-SM-36

PRODUCT SPECIFICATIONS

- Stainless Steel front and Sides
- 35,000 BTU Infra-red burner
- Manual gas control from 300°F to 1000°F
- Standing pilot igniton system
- Full width broiler pan
- 3/4" rear gas connection with regulator
- 3 Position Adjustable spring balanced rack
- Ball grip handle on adjustable rack for ease and comfort
- LP gas conversion kit included
- Ready to mount over any Core Pro 36 or 60 inch range
- 4" adjustable height, non-skid SS Legs included for countertop operation
- 1 year parts & labor warranty
- CP-SBWMT for direct wall mounting under exhaust hood (option - accessory)



CP-SM-36
MOUNTED ON BACK RISER OF CP-R36 RANGE
(SHOWN WITH OPTIONAL CASTERS)

Gas Salamander Broiler - Product Specifications

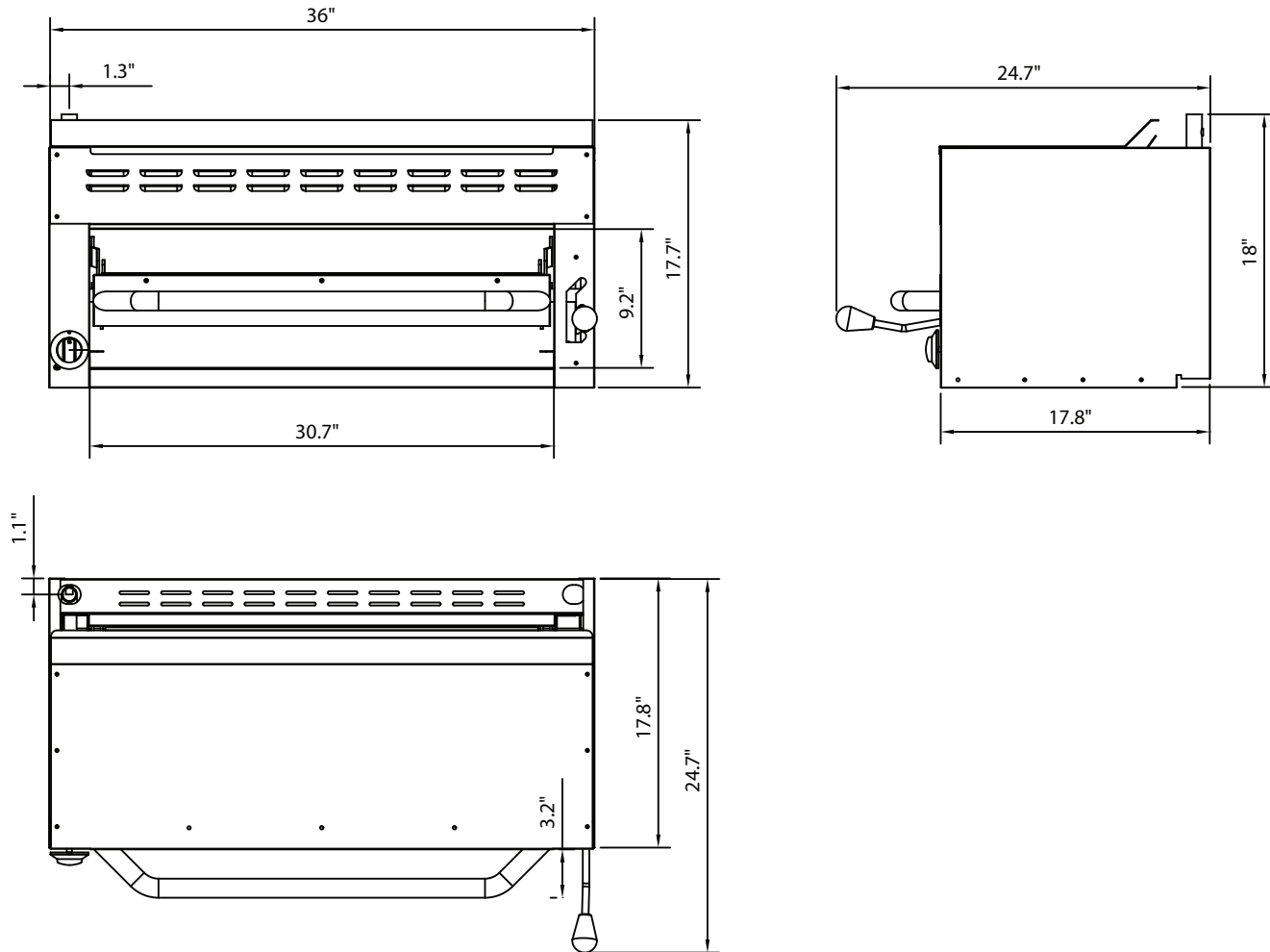

SPECIFICATIONS, DIMENSIONS & SHIPPING INFORMATION

Model	# of Burners	Total BTU	Overall Dimensions	Weight	Shipping Dimensions	Shipping Weight
CP-SM-36	1	35,000	36.0"L x 24.7"W x 18.0" H (91.4 cm x 62.7 cm x 45.7 cm)	143 lbs (65.0 kg)	39.4L x 25.6"W x 21.6"H (100 cm x 65 cm x 55 cm)	150 lbs (68.2 kg)

GAS REQUIREMENTS:

- Natural Gas or Liquid Propane (LP) Gas main supply required
- All units ship ready for Natural Gas. An LP conversion kit is included for converting to LP Gas. In order to avoid any warranty issues, conversion of your unit from Natural Gas to LP must be completed by an authorized Core Pro service agent.
- 3/4" NPT gas connection**
- Natural gas 4" W.C. , LP gas 10" W.C.**

